

STANDARD TOLERANCES	
OVERALL LENGTH	TOLERANCE
< 6"	+/- .25"
6" - 11"	+/- .50"
11" - 23"	+/- 1"
2.00' - 7.99'	+/- 2"
8.00' - 10.99'	+/- 3"
11.00' - 19.99'	+/- 4"
20.00' - 25.99'	+/- 6"
26.00' - 50.99'	+/- 8"
51.00' - 75.99'	+/- 10"
76.00' - 100.00'	+/- 12"
> 100.00'	+/- 1%

NOTE: TIGHTER TOLERANCES MAY REQUIRE SPECIAL FIXTURING AT ADDITIONAL COST

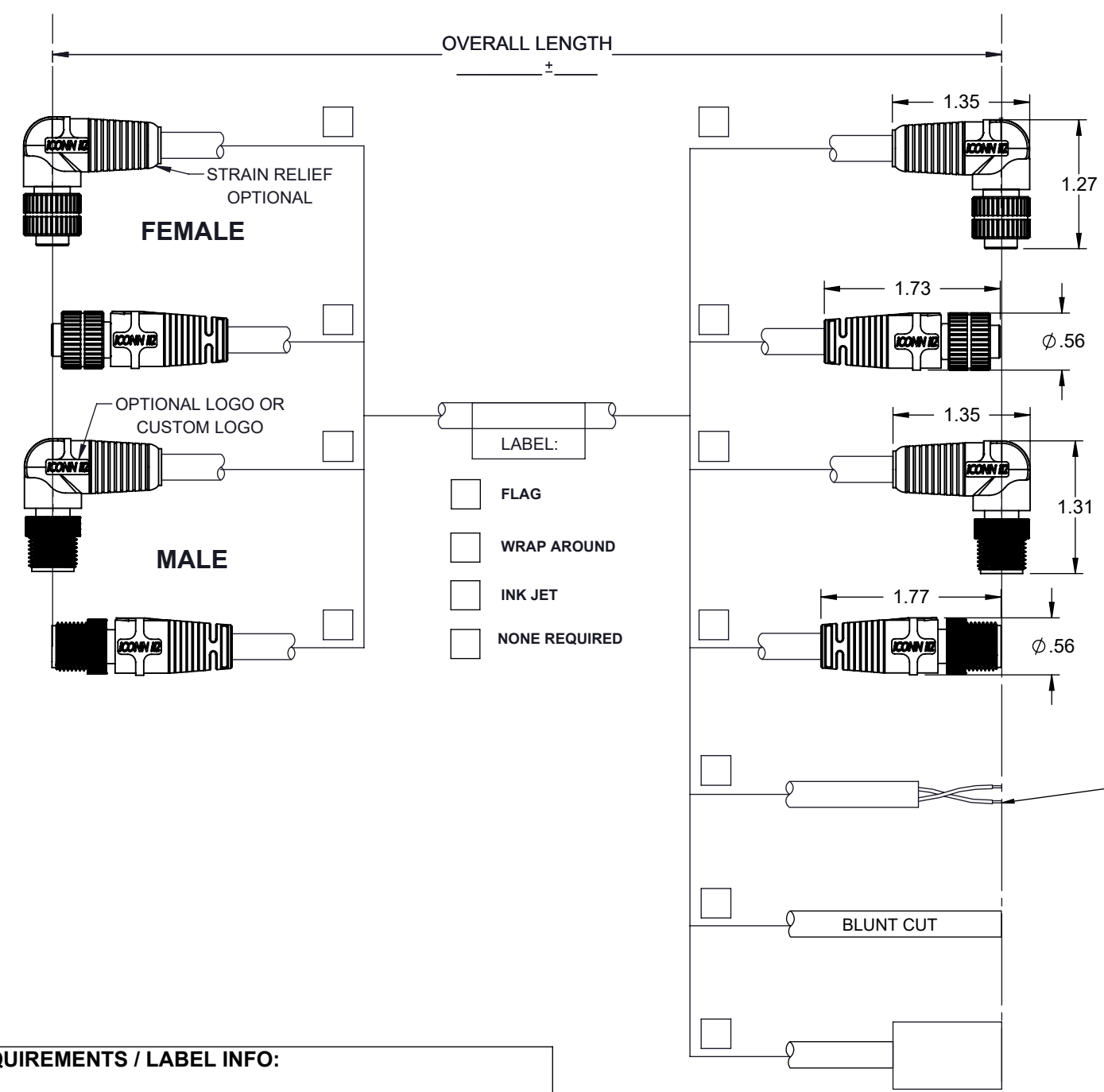
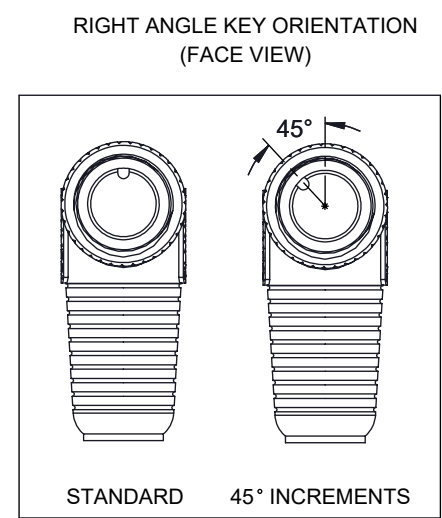

CABLE END PREP:
 • JACKET STRIP ____±____
 • WIRE STRIP ____±____
 • SLUG: YES NO
 • TIN: YES NO

SECONDARY INTERCONNECTION	
MFG	P/N

CABLE SPECIFICATION	
CABLE MFG / PART #:	
FILL OUT BELOW IF <u>NO</u> CABLE MFG OR PART #:	
JACKET COLOR:	
JACKET MATERIAL:	
CONDUCTOR SIZE:	
STRANDING:	
TINNED/BARE:	
# OF CONDUCTORS:	
CONDUCTOR INSULATION:	
SHIELD:	
DRAIN:	
VOLTS:	
UL:	
CSA:	
OTHER:	

SPECIAL REQUIREMENTS / LABEL INFO:	
OVERMOLD:	
OVERMOLD MATERIAL:	
I.P. RATING:	
OVERMOLD COLOR:	
UV RESIST: - YES / NO	
PACKAGING SPECS:	
1. IF LENGTH IS < 3FT. CABLE IS BUNDLED	
2. IF LENGTH IS > 3FT. CABLE IS COILED WITH I.D. =5" (UNLESS OTHERWISE SPECIFIED)	
3. MISC:	

ALL DIMENSIONS ARE SPECIFIED IN:
 IN [MM]
 TOLERANCES UNLESS OTHERWISE SPECIFIED:
 ENGLISH .XX = ±.02 IN .XXX = ±.010 IN
 METRIC .X = ±.2 MM .XX = ±.10 MM
 FRACTIONAL = ±1/64" ALL ANGLES = ±5°
 THIRD ANGLE PROJECTION

CONFIDENTIALITY NOTICE
 THIS DRAWING CONTAINS CONFIDENTIAL INFORMATION AND IS SUPPLIED BY ICONN SYSTEMS, LLC. THE OWNER OF SUCH INFORMATION. IN ACCEPTING THIS DRAWING, THE USER AGREES THAT IT IS FOR THE USER'S SOLE USE, THAT IT WILL NOT BE REPRODUCED OR DISTRIBUTED TO OTHERS, AND THAT THE INFORMATION CONTAINED THEREIN WILL NOT BE USED IN ANY MANNER DETRIMENTAL TO ICONN SYSTEMS.

DESIGNED BY: X.XXXXXX	DATE: XX-XX-XX
DESIGN APPROVED BY: X.XXXXXX	DATE: XX-XX-XX
DRAFTED BY: A. HERNANDEZ	DATE: 01-17-23
CHECKED BY: E. FREEMON	DATE: 01-17-23
SIZE B	DO NOT SCALE THIS DRAWING
DRAWING SCALE: 8:1	

1110 N. GARFIELD ST. LOMBARD, IL 60148
 TEL: (630) 827-6000 FAX: (630) 827-6006
ICONNSYSTEMS.COM

DRAWING TITLE:
i12 SALES OPTIONS

DRAWING NUMBER:
i12 TEMPLATE

DRAWING TYPE: SALES SHEET: 1 OF 2

REV. **A**

INSERT FACE VIEWS

A-CODE CONFIGURATIONS

B-CODE CONFIGURATIONS

D-CODE CONFIGURATIONS

(GREYED OUT HOLES ARE PRESENT BUT BLIND)

(GREYED OUT HOLES ARE PRESENT BUT BLIND)

# OF POLES	2 POLE	3 POLE	4 POLE	5 POLE	6 POLE	7 POLE	8 POLE	9 POLE	10 POLE	11 POLE	12 POLE	2 POLE	3 POLE	4 POLE	5 POLE	2 POLE	3 POLE	4 POLE	5 POLE
FEMALE FACE VIEW WITH KEYWAY (MALE IS REVERSE)																			
WIRE SIZE	20 - 24 AWG	20 - 24 AWG	20 - 24 AWG	20 - 24 AWG	22 - 26 AWG	22 - 26 AWG	22 - 26 AWG	24 - 28 AWG	24 - 28 AWG	24 - 28 AWG	24 - 28 AWG	20 - 24 AWG	20 - 24 AWG	20 - 24 AWG	20 - 24 AWG	20 - 24 AWG	20 - 24 AWG	20 - 24 AWG	20 - 24 AWG
END A/B																			
PIN/SOCKET																			

C-CODE CONFIGURATIONS

# OF POLES	2 POLE	3 POLE	4 POLE	5 POLE	6 POLE
FEMALE FACE VIEW WITH KEYWAY (MALE IS REVERSE)					
WIRE SIZE	20 - 24 AWG	20 - 24 AWG	20 - 24 AWG	22 - 26 AWG	22 - 26 AWG
END A/B					
PIN/SOCKET					

CONNECTOR CHECKLIST:

PAGE 1

- END A STYLE SELECTION
- END B STYLE SELECTION
- LABEL
- STRIP/TIN/SLUG
- OTHER INTERCONNECT
- CABLE SPECIFICATIONS
- OVERMOLD MATERIAL / COLOR / UV

PAGE 2

- END A PINOUT
- END A GENDER
- END B PINOUT (IF APPLICABLE)
- END B GENDER (IF APPLICABLE)
- WIRING TABLE

WIRE COLOR CODE END "A"

1	2	3	4	5	6	7	8	9	10	11	12
---	---	---	---	---	---	---	---	---	----	----	----

WIRE COLOR CODE END "B"

1	2	3	4	5	6	7	8	9	10	11	12
---	---	---	---	---	---	---	---	---	----	----	----

<p>ALL DIMENSIONS ARE SPECIFIED IN: IN [MM]</p> <p>TOLERANCES UNLESS OTHERWISE SPECIFIED: ENGLISH .XX = ±.02 IN .XXX = ±.010 IN METRIC .X = ±.2 MM .XX = ±.10 MM</p> <p>FRACTIONAL = ±1/64" ALL ANGLES = ±5°</p>		<p>DESIGNED BY: X.XXXXXX DATE: XX-XX-XX</p> <p>DESIGN APPROVED BY: X.XXXXXX DATE: XX-XX-XX</p> <p>DRAFTED BY: A. HERNANDEZ DATE: 01-17-23</p> <p>CHECKED BY: E. FREEMON DATE: 01-17-23</p>	<p>iconn an R2M co. SYSTEMS, LLC</p> <p>1110 N. GARFIELD ST. LOMBARD, IL 60148 TEL: (630) 827-6000 FAX: (630) 827-6006 ICONNSYSTEMS.COM</p>
<p>CONFIDENTIALITY NOTICE</p> <p>THIS DRAWING CONTAINS CONFIDENTIAL INFORMATION AND IS SUPPLIED BY ICONN SYSTEMS, LLC. THE OWNER OF SUCH INFORMATION. IN ACCEPTING THIS DRAWING, THE USER AGREES THAT IT IS FOR THE USER'S SOLE USE, THAT IT WILL NOT BE REPRODUCED OR DISTRIBUTED TO OTHERS, AND THAT THE INFORMATION CONTAINED THEREIN WILL NOT BE USED IN ANY MANNER DETRIMENTAL TO ICONN SYSTEMS.</p>		<p>DRAWING TITLE: i12 SALES OPTIONS</p>	
<p>SIZE B</p> <p>DO NOT SCALE THIS DRAWING</p>	<p>DRAWING SCALE: 8:1</p>	<p>DRAWING NUMBER: I12 TEMPLATE</p> <p>DRAWING TYPE: SALES SHEET: 2 OF 2</p>	

WIRING TABLE LEGEND:
N/T = NOT TERMINATED, N/C = NO CONTACT, M/C = MOLDED CLOSED